

CPH Series

Multilayer Ceramic Chip Capacitors – Safety Certified X¹Y² Capacitors

TRIGON
COMPONENTS



FEATURES

- TRIGON's Safety Certified Multilayer Ceramic chip capacitors are designed for surge or lightning immunity in modem facsimile and other equipments. The capacitors are class X1/Y2 compliant respectively.
- RoHS compliant per the standards defined by European Union Directive 2002/95/EC.
- The terminations are composed of plated nickel and pure tin to feature the superior leaching resistance during soldering.
- TUV safety certified (Certification# R500954240001).

ORDERING CODE

CPH 08 T 104 J 1Y2 N
(1) (2) (3) (4) (5) (6) (7)

- (1) Chip Capacitor
- (2) Size Code
- (3) Package
- (4) Capacitance Code
- (5) Tolerance Code
- (6) Class Type Code
- (7) Dielectric Code

※Please refer to complete Ordering Code (Multilayer Ceramic Chip Capacitor – P.B-191) for more ordering options.

Configuration

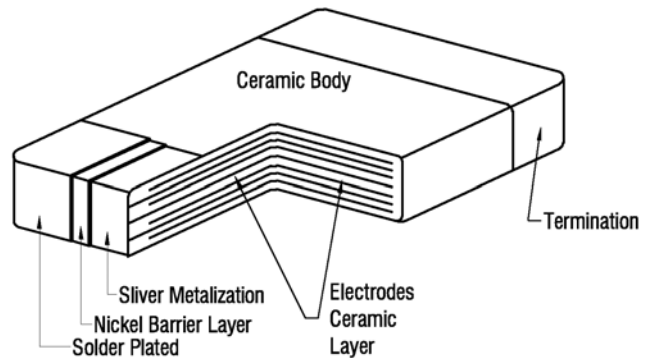

DIMENSIONS:

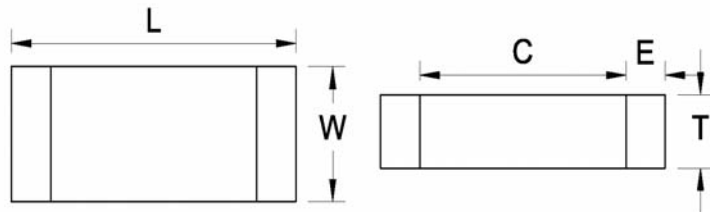

SIZE	L	W	T (max)	E
1808	4.60 ± 0.30	2.00 ± 0.20	2.20	0.64 ± 0.38
1812	4.60 ± 0.30	3.20 ± 0.30	2.70	0.64 ± 0.38
2211	5.70 ± 0.40	2.80 ± 0.30	2.70	0.85 ± 0.55

RATED CAPACITANCE LISTS:

SIZE	SAFETY RATING	STANDARD	AVAILABLE TOLERANCE	CAP.
1808	X1Y2	TUV	C,D,F,G,J,K,M,Z	*
1812	X1Y2	TUV	C,D,F,G,J,K,M,Z	*
2211	X1Y2	TUV	C,D,F,G,J,K,M,Z	*

*See Table 1 on Page B-187

CPH Series

Multilayer Ceramic Chip Capacitors – Safety Certified X¹Y² Capacitors

TRIGON
COMPONENTS

PERFORMANCE SPECIFICATION:

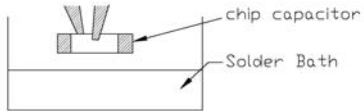
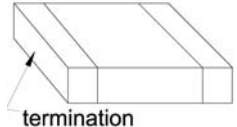
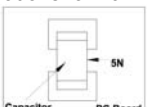
Test	Test Conditions	Post-Test Inspection Requirements
Temp. coefficient	Measured at 1KHz, 1V _{rms} , -55°C to +125°C	$\Delta C \leq +15\%$
Capacitance	Measured at 1KHz, 1V _{rms} , 25°C	Capacitance is within specified tolerance
Dissipation Factor (D.F.) and Tangent of Loss Angle ($\tan \delta$)	Measured at 1KHz, 1V _{rms} , 25°C	$\leq 2.5\%$
Insulation Resistance (I.R.)	After 60 sec charging at 500V (DC)	$\geq 10G\Omega$ or $\geq 100M\Omega \cdot \mu F$ Whichever is the less
Impulse Voltage	5.0KV	No breakdown or failure
Withstanding Voltage	Test 1.5KV AC for 60 sec.	No breakdown or failure
Solderability	Immersed in Solder bath at $245 \pm 5^\circ C$ for 5 ± 0.5 sec. 	No visible damage. At least 75% of termination area should be well tinned. 
Resistance to Soldering Heat	Immersed in solder bath at $260 \pm 5^\circ C$ for 10 ± 1 sec. Recovery: 24 ± 2 hr	No visible damage $\Delta C/C: \leq \pm 10\%$ I.R.: More than 1 G Ω D.F.: $\leq 5\%$
Endurance (Life Test)	Preconditioning 1000_{-0}^{+48} hr at upper category temperature applied at: $1.25 U_R$ (Y capacitor). Once every hour the voltage shall be increased to $1000V_{rms}$ for 0.1sec. Recovery: 24 ± 2 hr.	No visible damage after recovery: $\Delta C/C: \leq \pm 10\%$ I.R.: $\geq 1G\Omega$ or $50 M\Omega \cdot \mu F$ whichever is smaller D.F.: $\leq 5\%$
Humidity Test (Damp heat, steady state)	Preconditioning; 500_{-0}^{+24} hr at $40 \pm 2^\circ C$, 90~95% relative humidity. The capacitor with rated voltage ($250V_{ac}$) applied. Recovery: 24 ± 2 hr.	No visible damage after recovery: $\Delta C/C: \leq \pm 10\%$ I.R.: $\geq 1G\Omega$ or $50 M\Omega \cdot \mu F$ whichever is smaller D.F.: $\leq 5\%$
Adhesive strength of termination	Capacitors mounted on a substrate. A force of 5N applied perpendicular to the place of substrate and parallel the line joining the center of terminations for 10 ± 1 sec. 	No remove of the termination or other crack or visible damage.
Active Flammability	The capacitors applied U_i ($250V_{ac}$). Then each sample shall be subjected to 20 discharges from a tank capacitor, charge to a voltage that, when discharged, places U_i (5000V) across the capacitor under test. The interval between successive discharge shall be 5 sec.	The cheese cloth shall not burn with a flame.

CPH Series

Multilayer Ceramic Chip Capacitors – Safety Certified X¹Y² Capacitors

TRIGON
COMPONENTS

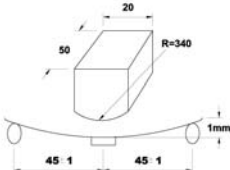
Test	Test Conditions	Post-Test Inspection Requirements
Resistance to flexure stress	<p>Capacitors mounted on a substrate. The board shall then be bent by 1mm at a rate of 1 mm/sec.</p> 	<p>No visible damage. Change in capacitance is less than 10%</p>

Capacitor

Table 1: Safety Certified Series

Size	1808		1812	2211
	X1/Y2 - TUV	X1/Y2 - TUV	X1/Y2 - TUV	X1/Y2 - TUV
	NPO	X7R	X7R	X7R
pF / WVDC	250	250	250	250
3.0				
4.7				
5.0				
5.6				
6.8				
8.2				
10				
12				
15				
18				
22				
27				
33				
39				
47				
56				
68				
82				
100				
120				
130				
150				
180				
220				
270				
300				
330				
390				
470				
560				
680				
820				
1000				
1200				
1500				
1800				
2200				
2700				
3300				
3900				
4700				
5600				
6800				
8200				

CPH Series

Multilayer Ceramic Chip Capacitors – Safety Certified X¹Y² Capacitors

TRIGON
COMPONENTS

PACKAGING:

1. BULK PACKAGE

All TRIGON Multilayer Ceramic Chip Capacitors are available in sealed plastic bag. The number of chips per bag depends on size and thickness of chip capacitors.

2. TAPE AND REEL PACKAGE

Taping is in accordance with EIA RS-481 or IEC 286-3

REEL FOR TAPING

Reel Dimensions: mm

Type	Width	A	N	C	D min	B min	G	T max
8		180	60±1.5	13.0±0.2	20.2	1.5	8.4 ^{+1.5} _{-0.0}	18.4
12		180	62±1.5	13.0±0.2	20.2	1.5	12.4 ^{+2.0} _{-0.0}	18.4

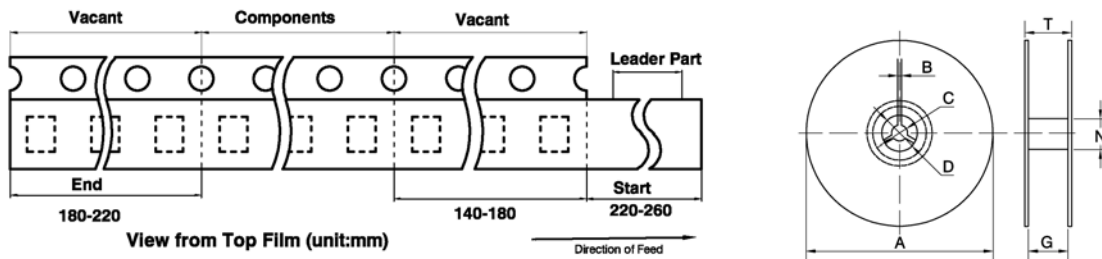

EMBOSSED TAPE DIMENSIONS:

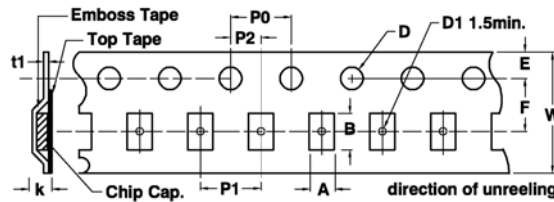

EMBOSSED TAPE: unit: mm

CODE	A	B	W	F	E	P1	P2	P0	D	t1	K
1808	2.4±0.2	4.90±0.2	12±0.3	5.5±0.10	1.75±0.1	4.0±0.1	2.0±0.10	4.0±0.1	1.50 ^{+0.1} _{-0.0}	0.6 max	2.8 max.
1812	3.6±0.2	4.90±0.2	12±0.3	5.5±0.10	1.75±0.1	8.0±0.1	2.0±0.10	4.0±0.1	1.50 ^{+0.1} _{-0.0}	0.6 max	2.8 max.
2211	3.2±0.2	6.10±0.2	12±0.3	5.5±0.10	1.75±0.1	4.0±0.1	2.0±0.10	4.0±0.1	1.50 ^{+0.1} _{-0.0}	0.6 max	2.8 max.

STANDARD PACKING per Reel for Embossed Tape (in 7" Reel)

Chip Size	1808			1812			2211	
Max. Carrier Thickness	1.55mm	1.80mm	2.20mm	1.80mm	2.20mm	2.70mm	2.20mm	2.70mm
Qty	1000	1000	2000	1000	1000	500	1000	500

CPH Series

Multilayer Ceramic Chip Capacitors – Safety Certified X¹Y² Capacitors

TRIGON
COMPONENTS

APPLICATION NOTES

Storage:

To prevent the damage of solderability of terminations, the following storage conditions are recommended:

Ambient temperature less than 40°C. Relative humidity less than 20% ~ 70% RH.

No harmful gases containing sulfur acid, ammonia, hydrogen sulfide or chlorine.

Packaging should not be opened until the capacitors are required for use. If opened, the pack should be re-sealed as soon as is practicable. Taped product should be stored out of direct sunlight, which might promote a deterioration in tape or adhesion performance. The capacitors should be used within 6 months. Checked the Solderability before use.

Handling:

Chip Capacitors are dense, hard brittle and abrasive materials. They are liable to suffer mechanical damage, in the form of cracks or chips. Chip capacitors should be handled with care to avoid contamination or damage. The use of vacuum picks up or plastic tweezers is recommended for manual placement. Tape and reeled packages are suitable for automatic pick and placement machine.

Preheat:

In order to minimize the risk of thermal shock during soldering, a carefully controlled preheat is required. The rate of preheat should not exceed 4°C per second and the final preheat temperature should be within 50°C of the soldering temperature for small chips such as 1808 etc..

Soldering:

Use mildly activated rosin RA and RMA fluxes, do not use activated flux. The amount of solder in each solder joint should be controlled to prevent the damage of chip capacitors caused by the stress between solder, chips and substrate.

Hand soldering with temperature-controlled iron not exceeding 30 watts and diameter of tip less than 1.2mm is recommended, tip of iron should not contact the ceramic body directly, and the temperature of iron should be set to not more than 260°C.

For bigger chips such as 1808 etc. wave soldering and hand soldering are not recommended.

Recommended soldering profiles as following:

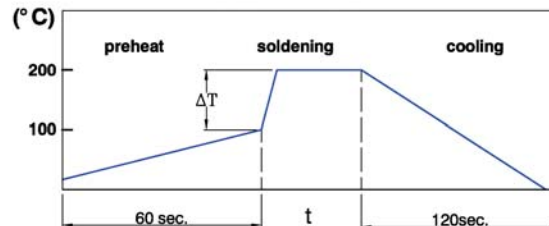

Soldering	Solder Temp.(T)	Soldering Time(t)
Reflow	235-250°C	<15 sec.
Wave	230-250°C	< 5 sec.

Chip Size	ΔT
1808	50°C

CPH Series

Multilayer Ceramic Chip Capacitors – Safety Certified X¹Y² Capacitors **TRIGON**
COMPONENTS

APPLICATION NOTES

Cooling:

After soldering, cool the chips and the substrate gradually to room temperature. Natural cooling in air is recommended to minimize stress in the solder joint. A cooling rate not exceeding 4°C per second should be used when cooling is necessary.

Cleaning

All flux residue must be removed by using suitable electronic-grade vapor-cleaning solvents to eliminate contaminations that could cause electrolytic surface corrosion. Good results can be obtained by using ultrasonic cleaning of the solvent. The choice of the proper system is dependent upon many factors such as component mix, flux, solder paste and assembly method. The ability of the cleaning system to remove flux residues and contamination from under the chips is very important.

Recommended Pad Dimensions:

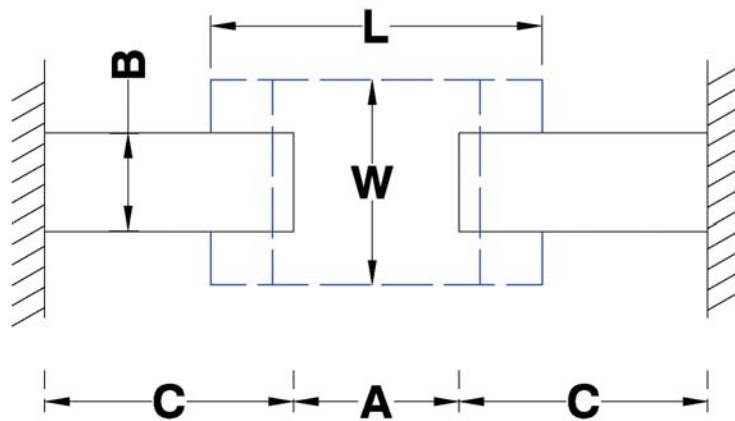

Unit: inches (mm)

Chip Size	L	W	A	B	C
1808	0.181 (4.6)	0.080 (2.0)	0.110~0.134 (2.8~3.4)	0.055~0.071 (1.4~1.8)	0.047~0.055 (1.2~1.4)

ORDERING CODE

Multilayer Ceramic Chip Capacitors

TRIGON
COMPONENTS

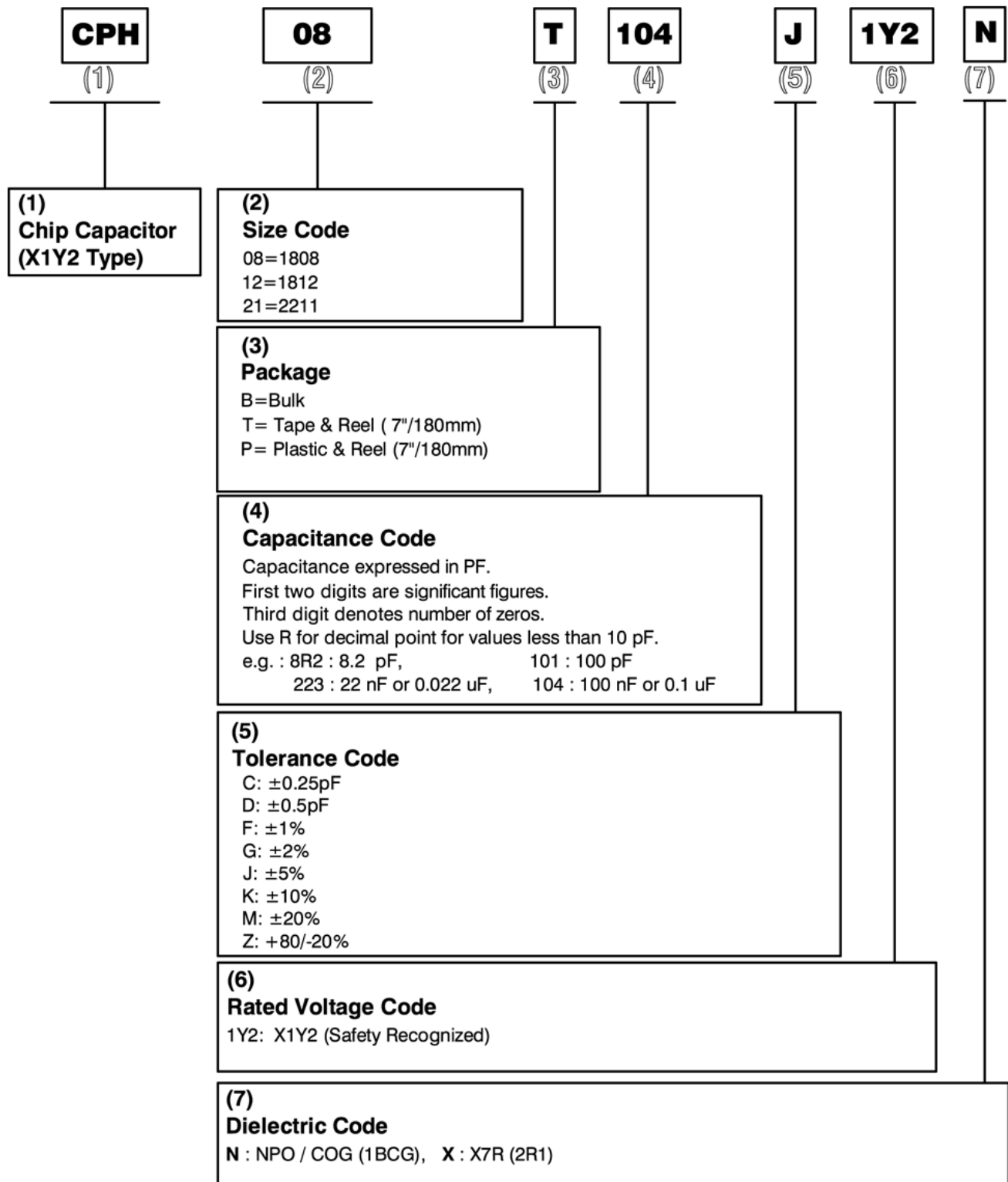

Capacitor