

## Ethernet PCMCIA Controller + COMBO Transceiver

### Features

- PCMCIA 2.01 bus interface.
- Use serial EEPROM 93C56/93C66 to store CIS.
- NE2000 compatible.
- IEEE 802.3 compatible.
- NS8390 Register compatible controller.
- Endec, UTP, AUI, and included.
- Auto media select between AUI and UTP.
- LED support for activity and Link.
- 100-pin LQFP package.
- Low Power CMOS process.
- TC3299A for UTP and AUI interface.

### General Description

The TC3299A (EPCC) is designed to reduce parts count and cost for easy implementation of PCMCIA CSMA/CD Local Area Networks. The TC3299A is the integration of the entire bus interface for PCMCIA BUS and which it includes Ethernet controller, Manchester Encoder/decoder, 10BaseT function and AUI interface. It complies with

IEEE 802.3 standards. TC3299A is compatible to NS8390 controller's register and Novell NE2000 industry Ethernet standard. To store CIS, TC3299A needs EEPROM 93C56/66 in PCMCIA LAN CARD to reduce part cost. Physical media 10BaseT, AUI interface are fully automatic detection. LED driver for Link and other activities are also provided.

10BaseT functional block includes receiver and transmitter, collision, loopback, jabber and link integrity. The Polarity Detection/Correction blocks are also defined as in the standard.

TC3299A uses analog Phase Lock Loop method for the Manchester encoding and the decoding method is specified by the IEEE 802.3 specification in the 10Mbit/sec transmission section. A collision detect translator and diagnostic Loopback Capability are also included in the TC3299A.

TC3299A is designed for conventional PCMCIA LAN CARD with AUI cable connecting to external MAU. TC3299A provides both UTP and AUI interface for maximum flexibility.

### Block Diagram

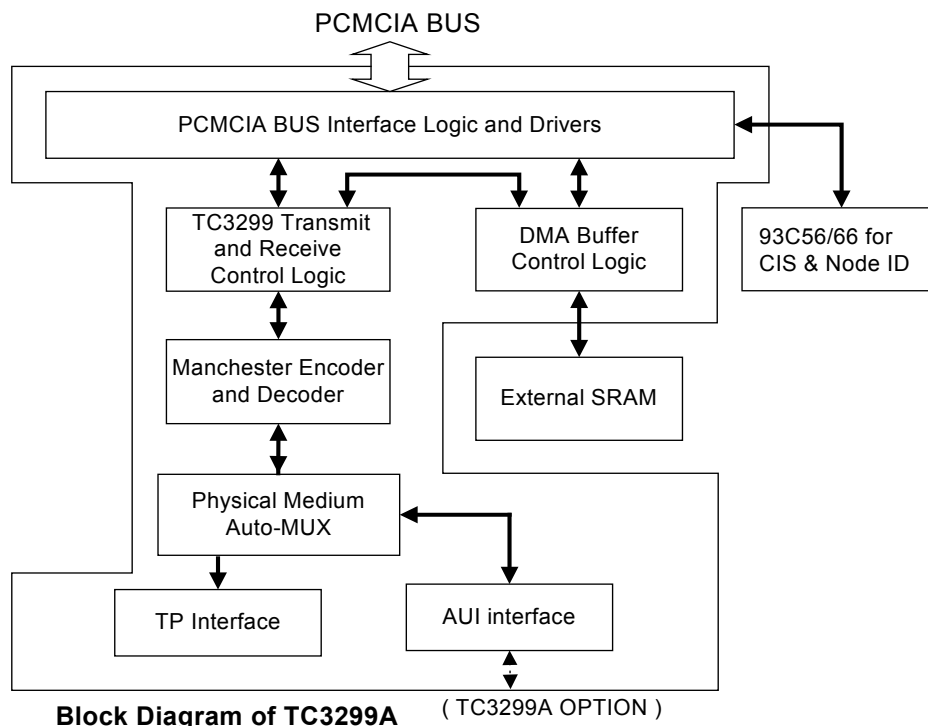



## Table Of Contents

Features .....	1
General Description .....	1
Block Diagram.....	1
Table Of Contents .....	2
Pin Configuration .....	3
1 Pin Description .....	4
2 Functional Description .....	7
2.1 Power On Configuration.....	9
3 Configuration Registers .....	11
3.1 EPCC Core Registers .....	12
4 Absolute Maximum Ratings.....	25
5 Standard Test Conditions .....	25
6 D.C. Characteristics.....	25
7 Physical Dimensions.....	26



### Pin Configuration

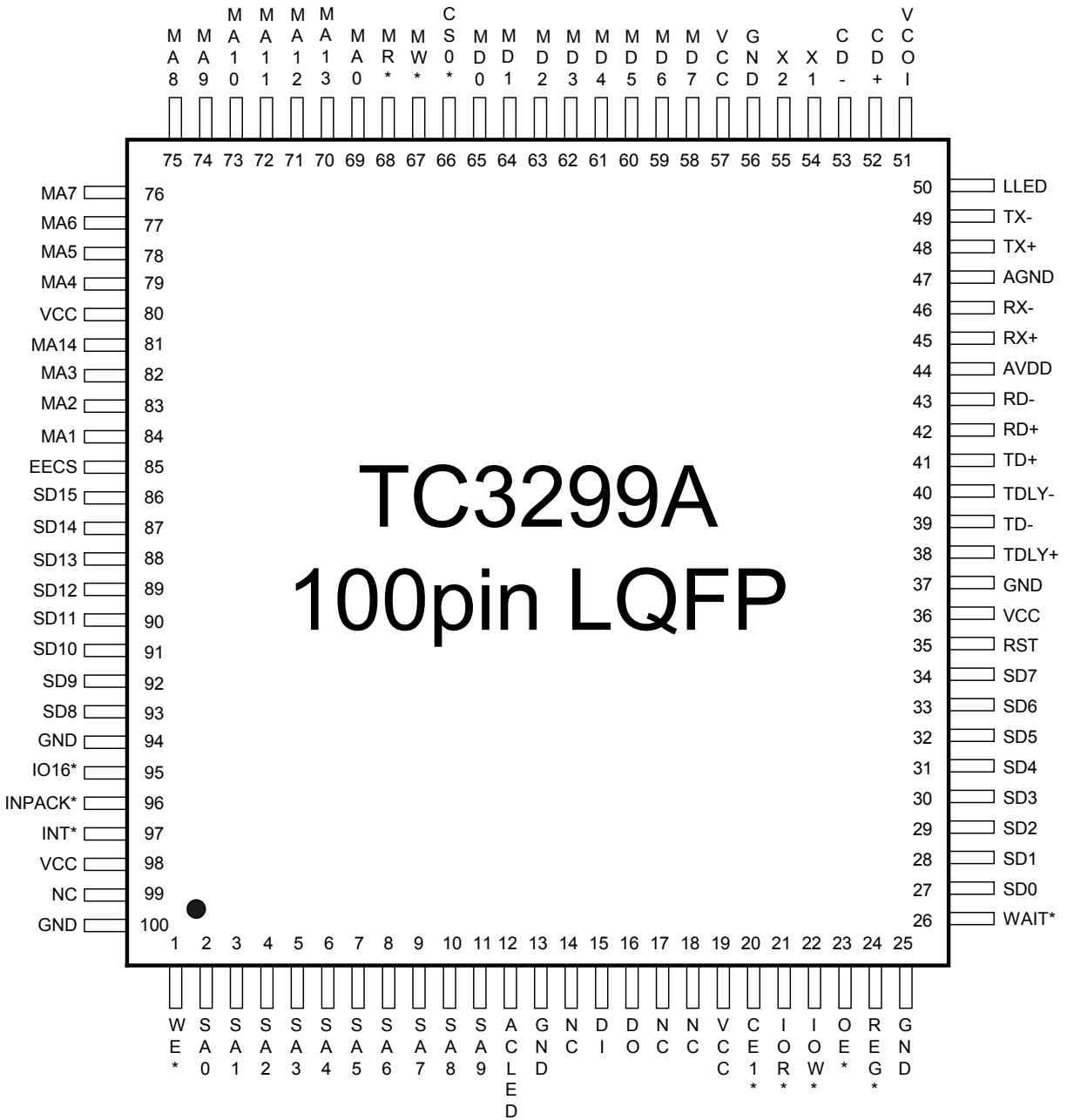



## 1 Pin Description

Pin No.	Symbol	I/O	Description									
<b>ISA Bus Interface Pins</b>												
2-11	SA0-SA9	I	These address signal lines of PCMCIA Bus are used to select a register to be read or written and attribute memory enable.									
27-34 93-86	SD0-SD7 SD8-SD15	I/O I/O	Register Access, with DMA inactive, SD0-SD7 pins are used to read/write register data. SD8-SD15 pins are invalid during this state. Remote DMA Bus Cycle, SD0-SD15 pins contain packet data. Direction of transfer is depended on Remote read/write.									
35	RST	I	Reset pin. RST is active high and placed EPCC in a reset mode immediately. During falling edge, the EPCC controller loads the configuration from MD0-7, MA0-13.									
26	WAIT*	O	This pin is set low to insert wait states during Remote DMA transfer.									
24	REG*	I	REG* is an active low input used to determine whether a lost access is to Attribute memory (The first 1K) or to common memory (above 1K). If REG* is set to low the access is to attribute memory, while REG* is set to high the access is to common memory. REG* is also asserted low for all accesses to the TC3299A's IO Registers.									
21	IOR*	I	Read Strobe: Strobe from host to read internal registers or Remote DMA read.									
22	IOW*	I	Write Strobe: Strobe from host to write internal registers or Remote DMA write.									
23	OE*	I	Host memory read strobe. The attribute memory can be read when OE* and REG* are both at low state. While for Common memory to be accessed, OE* should be set to low state and REG* should set to high state.									
			<table border="1"> <thead> <tr> <th></th> <th>OE*</th> <th>REG*</th> </tr> </thead> <tbody> <tr> <td>Attribute Memory</td> <td>Low</td> <td>Low</td> </tr> <tr> <td>Common Memory</td> <td>Low</td> <td>High</td> </tr> </tbody> </table>		OE*	REG*	Attribute Memory	Low	Low	Common Memory	Low	High
	OE*	REG*										
Attribute Memory	Low	Low										
Common Memory	Low	High										
1	WE*	I	Host memory write strobe. After Power reset, if TC3299A is configured to memory write enable, then 2 types of memories are written as defined below:									
			<table border="1"> <thead> <tr> <th></th> <th>WE*</th> <th>REG*</th> </tr> </thead> <tbody> <tr> <td>Attribute Memory</td> <td>Low</td> <td>Low</td> </tr> <tr> <td>Common Memory</td> <td>Low</td> <td>High</td> </tr> </tbody> </table>		WE*	REG*	Attribute Memory	Low	Low	Common Memory	Low	High
	WE*	REG*										
Attribute Memory	Low	Low										
Common Memory	Low	High										
96	INPACK*	O	Active low signal, asserted if the host access TC3299A internal register or Remote DMA read cycle.									
95	IO16*	O	IO16* is driven by EPCC to support host 16 bits access cycle.									
97	INT*	O	Interrupt:Indicates that the EPCC requires host attention after reception, transmission or completion of DMA transfer.									
20	CE1*	I	Card enable 1, are active low signals driven by the host. These signals provide a card select based on an address decode (decode by the host).									



Pin No.	Symbol	I/O	Description
<b>Memory Interface Pins</b>			
65-58	MD0-7	I/O	When RST is inactive these pins can be used to access external memory. When RST is active configuration is loaded with the data value on MD0-MD7 pins.
79-70 81 82-84, 69	MA4-13 MA14 MA3-1, MA0	I/O	When RST is inactive These pins drive the memory address bus during DMA access cycle. When RST is active configuration is loaded with the data value on MA0-MA13 pins.
68	MR*	O	Memory Bus Read: Strobes data from the buffer memory into the EPCC via the memory data bus.
67	MW*	O	Memory Bus Write: Strobes data from the EPCC into the external buffer memory via the memory data bus.
66	CS0*	O	Buffer RAM chip select, active low.
85	EECS	O	EEPROM chip select. It is asserted when to access EEPROM.
16	DO	I	Connected to EEPROM data output pin.
15	DI	O	Connected to EEPROM data input pin.

Pin No.	Symbol	I/O	Description
<b>Clock interface Pins</b>			
54	X1	I	Crystal or External Oscillator Input:20 MHz
55	X2	O	Crystal Feedback Output:Used in crystal connection only.

Pin No.	Symbol	I/O	Description
<b>Network Interface Pins</b>			
41,39	TD+/-	O	10BaseT differential transmit drivers.
38,40	TDLY+/-	O	10BaseT wave predistortion control differential outputs.
42,43	RD+/-	I	10BaseT differential receive input port.
51	VCOI	I	Filter input for data recover analog PLL.
50	LLED	O	Link integral LED driver. During Link loss, output high. During loading EEPROM data, used as Serial clock to the EEPROM.
12	ACLED	O	When power on reset, This pin must stay at high level. Otherwise, TC3299A will enter internal test mode. Active LED:(default) MA8 is open, when power reset. It functions as active indication LED driver. CLED: MA8 pull down during power reset. It works as Collision LED driver.

Pin No.	Symbol	I/O	Description
<b>Network Interface Pins(TC3299A option)</b>			
45,46	RX+/RX-	I	10Base5, Receiver input pair to controller.
48,49	TX+/TX-	O	10Base5, Transmit output pair from controller.
52,53	CD+/CD-	I	10Base5, Collision input pair to controller.



Pin No.	Symbol	I/O	Description
<b>Power Supply Pins</b>			
19,36,57,80,98	VCC		+5V DC is required. It is suggested that a decoupling capacitor be connected between VCC and GND.
13,25,37,56,94,100	GND		Power for analog Phase Lock Loop circuit of EPCC.
44	AVDD		
47	AGND		

## 2 Functional Description

The EPCC controller is a highly integrated jumperless configurable Ethernet controller. It integrates the function of the following blocks: TC3299A Ethernet Controller Core and Media Access Control logic.

1. PCMCIA 2.0 Bus interface containing all logics require to connect the TC3299A core to a packet buffer RAM and the PCMCIA Bus.
2. Serial EPROM interfaces, which loads Ethernet ID and Configuration Registers into the EPCC.
3. Physical media interface contains Encoder/Decoder with a 10BaseT Twisted Pair interface.

### I/O PORT ADDRESS MAPPING

This is compatible with Novell's NE2000. The base I/O address of EPCC Controller is configured by Configuration Registers (either upon power up or writing to this register by software). At that address the following structure appears.

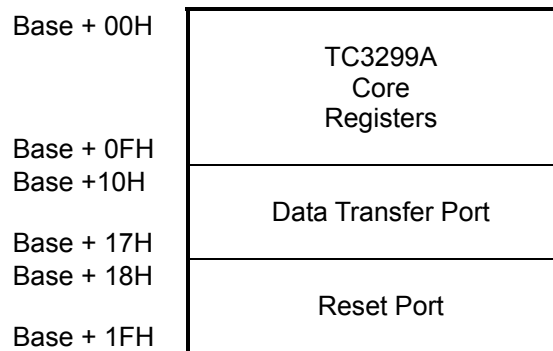

The registers within this area are 8 bits wide, but the data transfer port is 16 bits wide. By accessing the data transfer port (using I/O instructions) the user can transfer data to or from the EPCC Controller's internal memory. The EPCC Controller' internal memory map is as shown below.

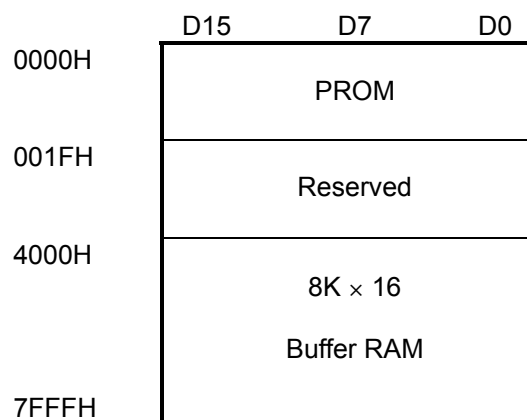

**EPCC Core 's Memory Map**

PROM Location	Location Contents
00h	ETHERNET ADDRESS 0
01h	ETHERNET ADDRESS 1
02h	ETHERNET ADDRESS 2
03h	ETHERNET ADDRESS 3



PROM Location	Location Contents
04h	ETHERNET ADDRESS 4
05h	ETHERNET ADDRESS 5
06-0Dh	RESERVED
0E,0Fh	57h
10-15h	ETHERNET ADDRESS 0-5
16-1Dh	RESERVED
1E-1Fh	42h

**Details of PROM Map**

EPCC Controller actually has a 64K address range but only does partial decoding on these devices. The PROM data is mirrored at all decodes up to 40000H and the entire map is repeated at 80000H. To access either the PROM or the RAM the user must initiate a Remote DMA transfer between the I/O port and memory.

**Remote Read/Write Cache:**

The EPCC Controller includes 4 words cache internally. On a remote read the EPCC Controller moves data from external memory buffer to the internal cache buffer; the EPCC moves data continuously until the cache buffer is full. On a remote write the system can writes data into the cache buffer until the 4 words cache buffer is full.

**PCMCIA CIS Structures & Decode Function:**

The TC3299A supports access to 1K of attribute memory. Attribute memory is defined by the PCMCIA standard to be comprised of the card 's information structure and four 8-bits Card Configuration Registers. These four registers are contained in the TC3299A. The attribute Memory (only even address can be accessed) map for a PCMCIA card is shown below.

7	0	
(Reserved)		3FEH
(Reserved)		3FCH
CCR1 (TC3299A)		3FAH
CCR0 (TC3299A)		3F8H
Reserved		3F0H-3F6H
Card 's information structure		2EEH 02 00

**Card Configuration Registers 0(R/W) (CCR0)**

7	6	5	4	3	2	1	0
RESET	XX	IOEN	XX	XX	XX	PJ1	PJ0

RESET : When this bit is set 1, a software reset to TC3299A.

IOEN : When this bit is set 1, the I/O operation is enabled.

PJ1,0 : If MA12 isn't pulled low during power on reset, despite of the value of PJ1,0, TC3299A response to I/O access at the I/O base address 300h, 320h, 340h, 360h. otherwise, I/O base Map as below:

PJ1	PJ0	I/O base Map
0	0	300h
0	1	320h
1	0	340h
1	1	360h

PJ1,0 : Reserved

### Configuration Registers 1 ® (CCR1)

7	6	5	4	3	2	1	0
XX	XX	XX	XX	XX	XX	IREQ	XX

IREQ : Controller interrupt status  
XX : Reserved

## 2.1 Power On Configuration

The EPCC Controller configures itself after a RST signal is applied. When a Power-On-Reset occurs the EPCC Controller latches the values on the configuration pins and uses these to configure the internal registers and options. Internally these pins contain pull-up resistance. If these configuration pins are unconnected the default logic will be applied. The configuration registers are loaded from the memory data bus when RST goes inactive.

A Power-On-Reset also causes the EPCC Controller to load the internal PROM store from the EEPROM, which can take up to 3 ms. This occurs after Config-Regs (Configuration registers?) have completed. If EECONFIG is high (MA9 pull down) the configuration data loaded on the falling edge of RST will be overwritten by the data read from the serial EEPROM. Regardless of the level on EECONFIG the PROM store will always be loaded with data from the serial EEPROM during the time specified as EELoad.

Figure 1 shows how the RESET circuitry operates.

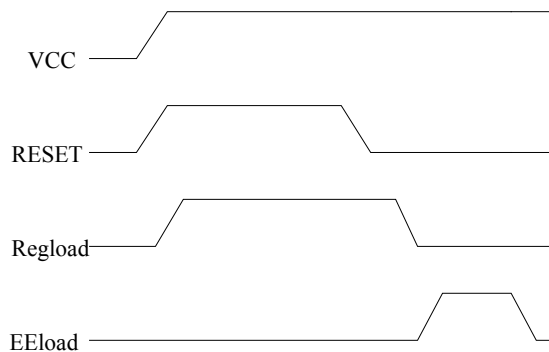

The EPCC Controller uses an 93C56/66, The programmed contents of the EEPROM is shown as following.

	D15	D0
.....	CIS byte n	CIS byte n-1
.....	.....	.....
16H	.....	.....
14H	.....	.....
12H	CIS byte 3	CIS byte 2

	D15	D0
10H	CIS byte 1	CIS byte 0
0FH	Not Used	Config. C
0EH	Config. B	Config. A
	Reserved	Reserved
08H	42H	42H
07H	57H	57H
04H	Reserved	Reserved
03H	Reserved	bit (0) : 8 bit enable bit (7:1) : Reserved
02H	E'net Address 5	E'net Address 4
01H	E'net Address 3	E'net Address 2
00H	E'net Address 1	E'net Address 0

**EEPROM Programming Map**

\*\*03H bit(0):If MA11 is pulled low during power on reset and this bit is set high. TC3299A can work at NE2000's 8-bit mode.

**Storing and Loading Configuration from EEPROM:**

If the EECONFIG is set high (MA9 pull low) during boot up, the EPCC Controller's configuration is determined by the EEPROM, before the PROM data is read

The configuration data is stored within the address 0EH of the EEPROM's address space. Configuration Register A and B are located in the address 0EH.

To write this configuration into the EEPROM, The user can program register in EPCC's address 02H of page 3. This operation will work regardless of the level on EECONFIG.

### 3 Configuration Registers

#### Configuration Register A (R/W)

To prevent any accidental write of this register, it is "hidden" behind a previously unused register. Register 0AH in the EPCC Controller's Page 0 of registers was previously reserved on a read. Now Configuration Register A can be read at that address and can be written to by following a read to 0AH with a write to 0AH.

If any other ENCC Controller register accesses take place between the read and the write then the write to 0AH will access the Remote Byte Count Register 0.

7	6	5	4	3	2	1	0
XX	FREAD	XX	XX	XX	XX	XX	XX

**FREAD** :The ENCC Controller supports 4 words Remote DMA read/write cache. When this bit is set high,Remote DMA cache control will be enabled.

**XX** :Reserved

#### Configuration Register B (R/W)

To prevent any accidental write of this register, it is "hidden" behind a previously unused register. Register 0BH in the EPCC Controller's Page 0 of registers was previously reserved on a read. Now Configuration Register B can be read at that address and can be written to by following a read to 0BH with a write to 0BH.

If any other ENCC Controller register accesses take place between the read and the write then the write to 0BH will access the Remote Byte Count Register 1.

7	6	5	4	3	2	1	0
XX	LINK	XX	XX	IO16CON	GDLINK	PHYS1	PHYS0

**PHYS1,0** : PHYSICAL LAYER INTERFACE

0	0	AUTO DETECT
0	1	Reserved
1	0	10Base5
1	1	10BaseT

In auto detect mode. For TC3299A, MA10 open for 10BaseT or 10Base5 auto-detect.

**GDLINK** : When this bit is high, to disable link test pulse generation and integrity checking.

**IO16CON** : When this bit is set high the Controller generates IO16\* after REG\* and CE1\* active. If low this output is generated only on address decode.

**LINK** : When this bit is high, link test integrity checking is Good. Otherwise, indicate link signal Loss.

**XX** : Reserved.

#### Configuration Register C

Can be load data from EEPROM only

7	6	5	4	3	2	1	0
XX	XX	XX	XX	XX	XX	CRDASEL	XX

**CRDASEL** : When this bit is high. CRDA0, CRDA1 increasing address control by internal cache state machine.





A0-A3	RD	WR
04H	Transmit Status Register (TSR)	Transmit Page Start Address (TPSR)
05H	Number of Collisions Register (NCR)	Transmit Byte Count Register 0 (TBCR0)
06H	FIFO (FIFO)	Transmit Byte Count Register 1 (TBCR1)
07H	Interrupt Status Register (ISR)	Interrupt Status Register (ISR)
08H	Current Remote DMA Address 0(CRDA0)	Remote Start Address Register 0 (RSAR0)
09H	Current Remote DMA Address 1 (CRDA1)	Remote Start Address Register 1 (RSAR1)
0AH	Config. Register A (CFGA)	Remote Byte Count Register 0 (RBCR0)
0BH	Config. Register B (CFGB)	Remote Byte Count Register 1 (RBCR1)
0CH	Receive Status Register (RSR)	Receive Configuration Register (RCR)
0DH	Tally Counter 0 (Frame alignment Errors) (CNTR0)	Transmit Configuration Register (TCR)
0EH	Tally Counter 1 (CRC errors) (CNTR1)	Data Configuration Register (DCR)
0FH	Tally Counter 2 (Missed Packet Errors) (CNTR2)	Interrupt Mask Register (IMR)

A0-A3	RD	WR
<b>Page 1 Address Assignments (PS1=0,PS0=1)</b>		
00H	Command (CR)	Command (CR)
01H	Physical Address Register 0(PAR0)	Physical Address Register 0(PAR0)
02H	Physical Address Register 1(PAR1)	Physical Address Register 1(PAR1)
03H	Physical Address Register 2(PAR2)	Physical Address Register 2(PAR2)
04H	Physical Address Register 3(PAR3)	Physical Address Register 3(PAR3)
05H	Physical Address Register 4(PAR4)	Physical Address Register 4(PAR4)
06H	Physical Address Register 5(PAR5)	Physical Address Register 5(PAR5)
07H	Current Page Register (CURR)	Current Page Register (CURR)
08H	Multicast Address Register 0(MAR0)	Multicast Address Register 0(MAR0)
09H	Multicast Address Register 1(MAR1)	Multicast Address Register 1(MAR1)
0AH	Multicast Address Register 2(MAR2)	Multicast Address Register 2(MAR2)
0BH	Multicast Address Register 3(MAR3)	Multicast Address Register 3(MAR3)
0CH	Multicast Address Register 4(MAR4)	Multicast Address Register 4(MAR4)
0DH	Multicast Address Register 5(MAR5)	Multicast Address Register 5(MAR5)
0EH	Multicast Address Register 6(MAR6)	Multicast Address Register 6(MAR6)
0FH	Multicast Address Register 7(MAR7)	Multicast Address Register 7(MAR7)



A0-A3	RD	WR
<b>Page 2 Address Assignments(PS1=1,PS0=0)</b>		
00H	Command(CR)	Command(CR)
01H	Page Start Register (PSTART)	Current Local DMA Address 0(CLDA0)
02H	Page Stop Register (PSTOP)	Current Local DMA Address 1(CLDA1)
03H	Remote Next Packet Pointer	Remote Next Packet Pointer
04H	Transmit Page Start Address(TPSR)	Reserved
05H	Local Next Packet Pointer	Local Next Packet Pointer
06H	Address Counter (Upper)	Address Counter (Upper)
07H	Address Counter (Lower)	Address Counter (Lower)
08H	Reserved	Reserved
09H	Reserved	Reserved
0AH	Reserved	Reserved
0BH	Reserved	Reserved
0CH	Receive Configuration Register(RCR)	Reserved
0DH	Transmit Configuration Register(TCR)	Reserved
0EH	Data Configuration Register(DCR)	Reserved
0FH	Interrupt mask Register(IMR)	Reserved

Note: Page 2 registers should only be accessed for diagnostic purposes. They should not be modified during normal operation. Page 3 Reserved should never be modified.

A0-A3	RD	WR
<b>Page 3 Address Assignments(PS1=1,PS0=1)</b>		
00H	Command(CR)	Command(CR)
01H	Reserved	Reserved
02H	Programming Reg.	Programming Reg.
03H	Reserved	Reserved
04H	Reserved	Reserved
05H	Reserved	Reserved
06H	Reserved	Reserved
07H	Reserved	Reserved
08H	Reserved	Reserved
09H	Reserved	Reserved
0AH	Reserved	Reserved
0BH	Reserved	Reserved
0CH	Reserved	Reserved
0DH	Reserved	Reserved
0EH	Reserved	Reserved
0FH	Reserved	Reserved



**REGISTER DESCRIPTIONS: Command Register (CR) (Read/Write)**

The Command Register is used to initiate transmissions, enable or disable Remote DMA operations and to select register pages. To issue a command the microprocessor sets the corresponding bit(s) (RD2, RD1, RD0, and TXP). Further commands may be overlapped, but with the following rules:(1) if a transmit command overlaps with a remote DMA operation, bits RD0, RD1, and RD2 must be maintained for the remote DMA command when setting the TXP bit. Note, if a remote DMA command is re-issued when giving the transmit command, the DMA will complete immediately if the remote byte count register have not been reinitialized. (2) If a remote DMA operation overlaps a transmission, RD0, RD1, and RD2 may be written with the desired values and a "0" to this bit has no effect. (3) A remote write DMA may not overlap remote read operation or visa versa. Either of these operations must either complete or be aborted before the other operation may start. Bits PS1, PS0, RD2, and STP may be set any time.

7	6	5	4	3	2	1	0
PS1	PS0	RD2	RD1	RD0	TXP	STA	STP

Bit	Symbol	Description																								
D0	STP	Stop: Software reset command, takes the controller offline, no packets will be received or transmitted. Any reception of transmission in progress will continue to completion before entering the reset state. To exit this state, the STP bit must be reset. The software reset is executed only when the RST bit in the ISR being set to a 1. STP powers up high.																								
D1	STA	Start: This bit is used to active the EPCC core after either power up, or when the EPCC cord has been placed in a reset mode by software command. STA power up low.																								
D2	TXP	Transmit Packet: This bit must be set to initiate transmission of a packet. TXP is internally reset either after the transmission is completed or aborted. This bit should be set only after the Transmit Byte Count and Transmit Page Start registers have been programmed. TXP powers up low.																								
D3-D5	RD0-RD2	Remote DMA Command: These three encoded bits control operation of the Remote DMA channel. RD2 can be set to about any Remote DMA command in progress. The Remote Start Addresses are not restored to the starting address if the Remote DMA is aborted. RD2 powers up high.  <table style="width: 100%; border-collapse: collapse;"> <tr> <td style="width: 15%;">RD2</td> <td style="width: 15%;">RD1</td> <td style="width: 15%;">RD0</td> <td style="width: 55%;"></td> </tr> <tr> <td>0</td> <td>0</td> <td>0</td> <td>Not Allowed</td> </tr> <tr> <td>0</td> <td>0</td> <td>1</td> <td>Remote Read</td> </tr> <tr> <td>0</td> <td>1</td> <td>0</td> <td>Remote Write (Note)</td> </tr> <tr> <td>0</td> <td>1</td> <td>1</td> <td>Send Packet</td> </tr> <tr> <td>1</td> <td>X</td> <td>X</td> <td>Abort/Complete Remote DMA (Note)</td> </tr> </table>	RD2	RD1	RD0		0	0	0	Not Allowed	0	0	1	Remote Read	0	1	0	Remote Write (Note)	0	1	1	Send Packet	1	X	X	Abort/Complete Remote DMA (Note)
RD2	RD1	RD0																								
0	0	0	Not Allowed																							
0	0	1	Remote Read																							
0	1	0	Remote Write (Note)																							
0	1	1	Send Packet																							
1	X	X	Abort/Complete Remote DMA (Note)																							
D6,D7	PS0,PS1	Page Select: Three two encoded bits select which register page is to be accessed with addresses A0-3.  <table style="width: 100%; border-collapse: collapse;"> <tr> <td style="width: 15%;">PS1</td> <td style="width: 15%;">PS0</td> <td style="width: 70%;"></td> </tr> <tr> <td>0</td> <td>0</td> <td>Register Page 0</td> </tr> <tr> <td>0</td> <td>1</td> <td>Register Page 1</td> </tr> <tr> <td>1</td> <td>0</td> <td>Register Page 2</td> </tr> <tr> <td>1</td> <td>1</td> <td>Register Page 3</td> </tr> </table>	PS1	PS0		0	0	Register Page 0	0	1	Register Page 1	1	0	Register Page 2	1	1	Register Page 3									
PS1	PS0																									
0	0	Register Page 0																								
0	1	Register Page 1																								
1	0	Register Page 2																								
1	1	Register Page 3																								

**Data Configure register (DCR)**

This Register is used to program the EPCC for 8 or 16-bit memory interfaces, select byte ordering in 16-bit applications and establish FIFO thresholds. The DCR must be initialized prior to load the Remote Byte count Registers.



7	6	5	4	3	2	1	0
-	FT1	FT0	ARM	LS	-	-	WTS

Bit	Symbol	Description																				
D0	WTS	Word Transfer Select 0: Selects byte-wide DMA transfers. 1: Selects word-wide DMA transfers Note: when word-wide mode is selected, up to 32k words are addressable; A0 remains low.																				
D1	-	Reserved																				
D2	-	Reserved																				
D3	LS	Loopback Select 0: Loopback mode selected. Bits D1,D2 of the TCR must also be programmed for Loopback mode selected. 1: Normal Operation.																				
D4	ARM	Auto-Initialize Remote 0: Send Command not executed, all packets removed from Buffer Ring under program control. 1: Send Command executed, Remote DMA auto-initialized to remove packets from Buffer Ring.																				
D5,D6	FT0,FT1	FIFO Threshold Select: Encoded FIFO threshold. During reception, the FIFO threshold indicates the number of bytes (or words) the FIFO has filled serially from the network before the FIFO is emptied onto memory bus. RECEIVE THRESHOLDS <table border="1"> <tr> <td>FT1</td> <td>FT0</td> <td>Word Wide</td> <td>Byte Wide</td> </tr> <tr> <td>0</td> <td>0</td> <td>1 Word</td> <td>2 Bytes</td> </tr> <tr> <td>0</td> <td>1</td> <td>2 Word</td> <td>4 Bytes</td> </tr> <tr> <td>1</td> <td>0</td> <td>4 Word</td> <td>8 Bytes</td> </tr> <tr> <td>1</td> <td>1</td> <td>6 Word</td> <td>12 Bytes</td> </tr> </table> During transmission, the FIFO threshold indicates the number of bytes (of words) the FIFO has filled from the Local DMA before being transferred to the memory. Thus, the transmission threshold is 16 bytes less the receive threshold.	FT1	FT0	Word Wide	Byte Wide	0	0	1 Word	2 Bytes	0	1	2 Word	4 Bytes	1	0	4 Word	8 Bytes	1	1	6 Word	12 Bytes
FT1	FT0	Word Wide	Byte Wide																			
0	0	1 Word	2 Bytes																			
0	1	2 Word	4 Bytes																			
1	0	4 Word	8 Bytes																			
1	1	6 Word	12 Bytes																			

### Transmit configuration Register (TCR)

The transmit configuration establishes the actions of the transmitter section of the EPCC during transmission of a packet on the network, LB1 and LB0 power up as 0.

7	6	5	4	3	2	1	0
-	-	-	OFST	ATD	LB1	LB0	CRC

Bit	Symbol	Description
D0	CRC	Inhibit CRC 0: CRC appended by transmitter 1: CRC inhibited by transmitter
D1,D2	LB0,LB1	Encoded Loopback Control: These encoded configuration bits set the type of loopback that should be performed. Note that loopback in mode 2 sets the LPBK pin high, this places the TC3096 in loopback mode and that D3 of the DCR must be set to zero for loopback operation.



Bit	Symbol	Description																				
		<table style="width: 100%; border-collapse: collapse;"> <tr> <td style="width: 15%;"></td> <td style="width: 15%; text-align: center;">LB1</td> <td style="width: 15%; text-align: center;">LB0</td> <td style="width: 55%;"></td> </tr> <tr> <td>Mode0</td> <td style="text-align: center;">0</td> <td style="text-align: center;">0</td> <td>Normal Operation (LPBK=0)</td> </tr> <tr> <td>Mode1</td> <td style="text-align: center;">0</td> <td style="text-align: center;">1</td> <td>Internal Loopback (LPBK=0)</td> </tr> <tr> <td>Mode2</td> <td style="text-align: center;">1</td> <td style="text-align: center;">0</td> <td>External Loopback (LPBK=1)</td> </tr> <tr> <td>Mode3</td> <td style="text-align: center;">1</td> <td style="text-align: center;">1</td> <td>External Loopback (LPBK=0)</td> </tr> </table>		LB1	LB0		Mode0	0	0	Normal Operation (LPBK=0)	Mode1	0	1	Internal Loopback (LPBK=0)	Mode2	1	0	External Loopback (LPBK=1)	Mode3	1	1	External Loopback (LPBK=0)
	LB1	LB0																				
Mode0	0	0	Normal Operation (LPBK=0)																			
Mode1	0	1	Internal Loopback (LPBK=0)																			
Mode2	1	0	External Loopback (LPBK=1)																			
Mode3	1	1	External Loopback (LPBK=0)																			
D3	ATD	Auto Transmit Disable: This bit allows another station to disable the EPCC'S transmitter by transmission of a particular multicast packet. The transmitter can be re-enabled by resetting this bit or by reception of a second particular multicast packet. 0: Normal Operation 1: Reception of multicast address hashing to 62 bit disables transmitter, reception of multicast address hashing to bit 63 enables transmitter.																				
D4	OFST	Collision Offset Enable: This bit modifies the back off algorithm to allow prioritization of nodes. 0: Backoff Logic implements normal algorithm. 1: Forces Backoff algorithm modification to 0 to $2^{\text{min}(3+n,10)}$ slot times for first three collisions, Then follows standard backoff. (For first three collisions station has higher average backoff delay making a low priority mode.)																				
D5	-	Reserved																				
D6	-	Reserved																				
D7	-	Reserved																				

**Transmit Status Register (TSR)**

This register records events that occur on the media during transmission of a packet. It is cleared when the host initiates the next transmission. All bits remain low unless the event that corresponds to a particular bit occurs during transmission. Each transmission should be followed by a read of this register. The contents of this register are not specified until after the first transmission.

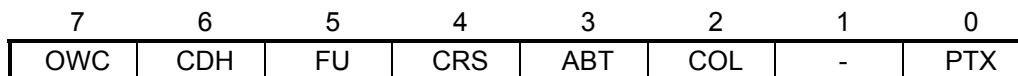

Bit	Symbol	Description
D0	PTX	Packet Transmitted: Indicates transmission without error (No excessive collisions or FIFO underrun) (ABT="0",FU="0").
D1	-	Reserved
D2	COL	Transmit Collided: Indicates that the transmission collided at least once with another station on the network. The number of collisions is recorded in the Number of Collisions Registers. (NCR).
D3	ABT	Transmit Aborted: Indicates the EPCC aborted transmission because of excessive collisions. (Total number of transmissions including original transmission attempt equals 16).
D4	CRS	Carrier Sense Lost: This bit is set when carrier is lost during transmission of the packet. Carrier Sense is monitored from the end of Preamble/ Synch until TXE is dropped. Transmission is not aborted on loss of carrier.
D5	FU	FIFO Underrun: If the EPCC cannot gain access of the bus before the FIFO empties, this bit is set. Transmission of the packet will be aborted.



D6	CDH	CD Heartbeat: Failure of the transceiver to transmit a collision signal after transmission of a packet will set this bit. The Collision Detect (CD) heartbeat signal must commence during the first 6.4us of the Interframe Gap following a transmission. In certain collisions, the CD Heartbeat bit will be set even though the transceiver is not performing the CD heartbeat test.
D7	OWC	Out of Window Collision: Indicates that a collision occurred after a slot time (51.2us). Transmissions rescheduled as in normal collisions.

### Receive Configuration Register (RCR)

This register determines operation of the EPCC during reception of a packet and is used to program what types of packets to accept.

7	6	5	4	3	2	1	0
-	-	MON	PRO	AM	AB	AR	SEP

Bit	Symbol	Description
D0	SEP	Save Errored Packets 0: Packets with receive errors are rejected. 1: Packets with receive errors are accepted. Receive errors are CRC and Frame Alignment errors.
D1	AR	Accept Runt Packets 0: Packets with fewer than 64 bytes rejected. 1: Packets with fewer than 64 bytes accepted.
D2	AB	Accept Broadcast 0: Packets with all 1's broadcast destination address rejected. 1: Packets with all 1's broadcast destination address accepted.
D3	AM	Accept Multicast 0: Packets with multicast destination address not checked. 1: Packets with multicast destination address checked.
D4	PRO	Promiscuous Physical 0: Physical address of node must match the station address programmed in PAR0-PAR5. (Physical address checked) 1: All packets with any physical address accepted. (physical address not checked)
D5	MON	Monitor Mode: Enables the receiver to check addresses and CRC on incoming packets without buffering to memory. The missed packet Tally counter will be incremented for each recognized packet. 0: Packets buffered to memory. 1: Packets checked for address match, good CRC and frame Alignment but not buffered to memory.
D6	-	Reserved
D7	-	Reserved

Note: D2 and D3 are "OR'd" together, i.e., if D2 and D3 are set the EPCC will accept broadcast and multicast addresses as well as its own physical address. To establish full promiscuous (non discrimination) mode, bits D2, D3 and D4 should be set. In addition the multicast hashing array must be set to all 1's in order to accept all multicast addresses.

### Receive Status Register (RSR)



This register records status of the received packet, including information on errors and the type of address match, either physical or multicast. The contents of this register are written to buffer memory by the DMA after reception of a good packet. If packets with errors are to be saved the receive status is written to memory at the head of the erroneous packet if an erroneous packet is received. If packets with errors are to be rejected the RSR will not be written to memory. The contents will be cleared when the next packet arrives. CRC errors, frame Alignment errors and missed packets are counted internally by the EPCC which relinquishes the Host from reading the RSR in real time to record errors for Network Management functions. The contents of this register are not specified until after the first reception.

7	6	5	4	3	2	1	0
DFR	DIS	PHY	MPA	FO	FAE	CRC	PRX

Bit	Symbol	Description
D0	PRX	Packet Received Intact: Indicates packet received without error. (Bits CRC, FAE, FO and MPA are zero for the received packet.)
D1	CRC	CRC Error: Indicates packet received with CRC error. Increments Tally Counter (CNTR1). This bit will also be set for Frame Alignment errors.
D2	FAE	Frame Alignment Error: Indicates that the incoming packet did not end on a byte boundary and the CRC did not match at last byte boundary. Increments Tally counter (CNTR0).
D3	FO	FIFO Overrun: This bit is set when the FIFO is not serviced causing overflow during reception. Reception of the packet will be aborted.
D4	MPA	Missed Packet: Set when packet intended for node cannot be accepted by EPCC because of a lack of receive buffers or if the controller is in monitor mode and did not buffer the packet to memory. Increments Tally Counter (CNTR2).
D5	PHY	Physical/Multicast Address: Indicates whether received packet had a physical or multicast address type 0: Physical Address Match 1: Multicast/Broadcast Address Match
D6	DIS	Receiver Disabled: Set when receiver disabled by entering Monitor mode. Reset when receiver is re-enabled when exiting Monitor mode.
D7	DFR	Deferring: Set when CRS or COL inputs are active. If the transceiver has asserted the CD line as a result of the jabber, this bit will stay set indicating the jabber condition.

Note: Following coding applies to CRC and FAE bits

FAE	CRC	Type of Error
0	0	No error (Good CRC and <6 Dribble Bits)
0	1	CRC ERROR
1	0	Legal, will not occur
1	1	Frame Alignment Error and CRC Error

### Interrupt Mask Register (IMR)

The interrupt Mask Register is used to mask interrupts. Each interrupt mask bit corresponds to a bit in the Interrupt Status Register (ISR). If an interrupt mask bit is set an interrupt will be issued whenever the corresponding bit in the ISR is set. If any bit in the IMR is set low, an interrupt will not occur when the bit in the ISR is set. The IMR powers up all zeroes.

7	6	5	4	3	2	1	0
-	RDCE	CNTE	OVWE	TXEE	RXEE	PTXE	PRXE



Bit	Symbol	Description
D0	PRXE	Packet Received Interrupt Enable: Enables Interrupt when packet received.
D1	PTXE	Packet Transmitted Interrupt Enable: Enables Interrupt when packet is transmitted.
D2	RXEE	Receive Error Interrupt Enable: Enables Interrupt when packet received with error.
D3	TXEE	Transmit Error Interrupt Enable: Enables Interrupt when packet transmission results in error.
D4	OVWE	Over Write Warning Interrupt Enable: Enables Interrupt when Buffer management Logic lacks sufficient buffers to store incoming packet.
D5	CNTE	Counter Overflow Interrupt Enable: Enables Interrupt when MSB of one or more of the Network Tally counters has been set.
D6	RDCE	DMA Complete Interrupt Enable: Enables Interrupt when Remote DMA transfer has been completed.
D7	-	Reserved

### Interrupt Status Register (ISR)

This register is accessed to determine the cause of an interrupt. Any interrupt can be masked in the interrupt Mask Register (IMR). Individual interrupt bit is cleared by writing a "1" into the corresponding bit of the ISR. The IRQ signal is active as long as any unmasked signal is set, and will not go low until all unmasked bits in this register have been cleared. The ISR must be cleared after power up by writing it with all 1's.

7	6	5	4	3	2	1	0
RST	RDC	CNT	OVW	TXE	RXE	PTX	PRX

Bit	Symbol	Description
D0	PRX	Packet Received: Indicates packet received with no errors.
D1	PTX	Packet Transmitted: Indicates packet transmitted with no errors.
D2	RXE	Receive Error: Indicates that a packet was received with one or more of the following errors: - CRC Error - Frame Alignment Error - FIFO Overrun - Missed Packet
D3	TXE	Transmit Error: Set when packet transmitted with one or more of the following errors: - Excessive Collisions - FIFO Underrun
D4	OVW	Over Write Warning: Set when receive buffer ring storage resources have been exhausted. (Local DMA has reached Boundary Pointer).
D5	CNT	Counter Over flow: Set when MSB of one or more of the Network Tally Counters has been set.
D6	RDC	Remote DMA Complete: Set when Remote DMA operation has been completed.
D7	RST	Reset Status: A status indicator with no interrupt generated - Set when EPCC enters reset state and is cleared when a start command is issued - Set when a Receive Buffer Ring overflows and is cleared when leaves overflow status. Writing to this bit has no effect and powers up high.

### Network Tally Counter Registers (CNTR)

Three 8-bit counters are provided for monitoring the number of CRC errors, Frame Alignment Errors and missed packets, The maximum count reached by any counter is 192 (C0H). These registers will be cleared when read by the CPU. The count is recorded in binary in CT0-CT7 of each Tally Register.

CNTR0: Monitor the number of Frame Alignment error

7	6	5	4	3	2	1	0
CT7	CT6	CT5	CT4	CT3	CT2	CT1	CT0

CNTR1: Monitor the number of CRC error

7	6	5	4	3	2	1	0
CT7	CT6	CT5	CT4	CT3	CT2	CT1	CT0

CNTR2: Monitor the number of Missed Packets

7	6	5	4	3	2	1	0
CT7	CT6	CT5	CT4	CT3	CT2	CT1	CT0

### Number of Collisions Register (NCR)

This register contains the number of collisions a node experiences when attempting to transmit a packet. If no collisions are experienced during a transmission attempt, the COL bit of the TSR will be set and the contents of NCR will be zero. If there are excessive collisions, the ABT bit in the TSR will not be set and the contents of NCR will be zero. The NCR is cleared after the TXP bit in the CR is set.

7	6	5	4	3	2	1	0
-	-	-	-	NC3	NC2	NC1	NC0

### FIFO Register (FIFO)

This is an 8-bit register that allows the CPU to examine the contents of the FIFO after loopback. The FIFO will contain the last 8 data bytes transmitted in the loopback packet. Sequential reads from the FIFO will advance a pointer in the FIFO and allow reading of all 8 bytes. Note that the FIFO should only be read when the EPCC has been programmed in loopback mode.

7	6	5	4	3	2	1	0
DB7	DB6	DB5	DB4	DB3	DB2	DB1	DB0

### Physical Address Registers (PAR0-PAR5)

The physical address registers are used to compare the destination address of incoming packets for rejecting or accepting packets. Comparisons are performed on a byte-wide basis. The bit assignment shown below relates the sequence in PAR0-PAR5 to the bit sequence of the received packet.

	..	Syn	Syn	DA0	DA1	DA2	DA3	DA4	DA5	DA6	DA7	..
	----- DestinationAddress -----										Source	
	D7	D6	D5	D4	D3	D2	D1	D0				
PAR0	DA7	DA6	DA5	DA4	DA3	DA2	DA1	DA0				
PAR1	DA15	DA14	DA13	DA12	DA11	DA10	DA9	DA8				
PAR2	DA23	DA22	DA21	DA20	DA19	DA18	DA17	DA16				
PAR3	DA31	DA30	DA29	DA28	DA27	DA26	DA25	DA24				
PAR4	DA39	DA38	DA37	DA36	DA35	DA34	DA33	DA32				
PAR5	DA47	DA46	DA45	DA44	DA43	DA42	DA41	DA40				



### Multicast Address Registers (MAR0-MAR70)

The Multicast address registers provide filtering of multicast addresses hashed by the CRC logic. All destination addresses are fed through the CRC logic and as the last bit of the destination address enters the CRC, the 6 most significant bits of the CRC generator are latched. These 6 bits are then decoded by a 1 of 64 decode to index a unique filter bit (FB0-63) in the multicast address register. If the filter bit selected is set, the multicast packet is accepted. The system designer would use a program to determine which filter bits to set in the multicast registers. For some address found to hash to the value 50 (32H), then FB50 in MAR6 should be initialized to "1". All multicast filter bits that correspond to multicast address accepted by the node are then set to one. To accept all multicast packets all of the registers are set to all ones.

	D7	D6	D5	D4	D3	D2	D1	D0
MAR0	FB7	FB6	FB5	FB4	FB3	FB2	FB1	FB0
MAR1	FB15	FB14	FB13	FB12	FB11	FB10	FB9	FB8
MAR2	FB23	FB22	FB21	FB20	FB19	FB18	FB17	FB16
MAR3	FB31	FB30	FB29	FB28	FB27	FB26	FB25	FB24
MAR4	FB39	FB38	FB37	FB36	FB35	FB34	FB33	FB32
MAR5	FB47	FB46	FB45	FB44	FB43	FB42	FB41	FB40
MAR6	FB55	FB54	FB53	FB52	FB51	FB50	FB49	FB48
MAR7	FB63	FB62	FB61	FB60	FB59	FB58	FB57	FB56

### DMA Registers

#### LOCAL DMA TRANSMIT REGISTERS

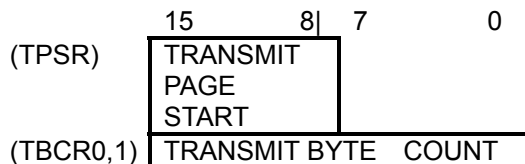

#### LOCAL DMA RECEIVE REGISTERS

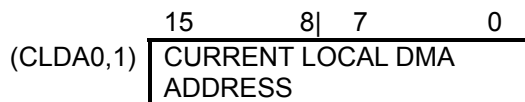
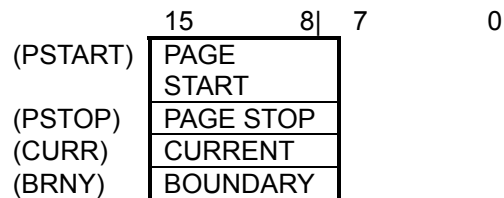

#### REMOTE DMA REGISTERS

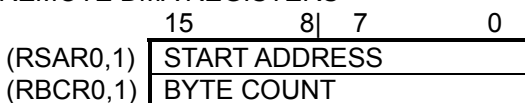

**(I) Local DMA Transmit Registers**

Transmit page start register (TPSR):

This register points to the assembled packet to be transmitted. Only the eight higher order addresses are specified since all transmit packets are assembled on 256-byte page boundaries.

	7	6	5	4	3	2	1	0
	A15	A14	A13	A12	A11	A10	A9	A8

Transmit byte count register0,1 (TBCR0,TBCR1):

These two registers indicate the length of the packet to be transmitted in bytes. The maximum number of transmit bytes allowed is 64k bytes. The EPCC will not truncate transmissions longer than 1500 bytes.

	7	6	5	4	3	2	1	0
TBCR1	L15	L14	L13	L12	L11	L10	L9	L8

	7	6	5	4	3	2	1	0
TBCR0	L7	L6	L5	L4	L3	L2	L1	L0

**(II) Local DMA Receive Registers**

Page start, stop registers (PSTART, STOP):

The Page Start and Page stop Registers program the starting and stopping page of the Receive Buffer Ring. Since the EPCC uses fixed 256-byte buffers aligned on page boundaries only the upper eight bits of the start and stop address are specified.

	7	6	5	4	3	2	1	0
PSTART	A15	A14	A13	A12	A11	A10	A9	A8
PSTOP								

Boundary register (BNRY):

This register is used to prevent overflow of the Receive Buffer Ring. Buffer management compares the contents of this register to the next buffer address when linking buffers together. If the contents of this register match the next buffer address the local DMA operation is aborted.

	7	6	5	4	3	2	1	0
BNRY	A15	A14	A13	A12	A11	A10	A9	A8

**(III) Remote DMA registers**

Remote Start Address Registers (RSAR0,1):

Remote Byte Count Registers (RBCR0,1):

Remote DMA operations are programmed via the Remote Start Address (RSAR0,1) and Remote Byte Count (RBCR0,1) registers. The Remote Start Address is used to point to the start of the block of data to be transferred and the Remote Byte Count is used to indicate the length of the block (in bytes).

	7	6	5	4	3	2	1	0
RSAR1	A15	A14	A13	A12	A11	A10	A9	A8

	7	6	5	4	3	2	1	0
RSAR0	A7	A6	A5	A4	A3	A2	A1	A0



	7	6	5	4	3	2	1	0
RBCR1	BC15	BC14	BC13	BC12	BC11	BC10	BC9	BC8

	7	6	5	4	3	2	1	0
RBCR0	BC7	BC6	BC5	BC4	BC3	BC2	BC1	BC0

**Current Page Register:**

The Buffer Management Logic uses this register internally; it is used as a backup register for reception. CURR contains the address of the first buffer to be used for a packet reception and is used to restore DMA pointers in the event of receive errors. This register is initialized to the same value as PSTART and should not be written to again unless the controller is reset.

	7	6	5	4	3	2	1	0
CURR	A15	A14	A13	A12	A11	A10	A9	A8

**Current local DMA register 0,1 (CLDA0,1):**

These two registers can be accessed to determine the current Local DMA Address.

	7	6	5	4	3	2	1	0
CLDA1	A15	A14	A13	A12	A11	A10	A9	A8

	7	6	5	4	3	2	1	0
CLDA0	A7	A6	A5	A4	A3	A2	A1	A0

**Current Remote DMA Address Registers:**

The Current Remote DMA Registers contain the current address of the Remote DMA. The bit assignment is shown below:

	7	6	5	4	3	2	1	0
CRDA1	A15	A14	A13	A12	A11	A10	A9	A8

	7	6	5	4	3	2	1	0
CRDA0	A7	A6	A5	A4	A3	A2	A1	A0



#### 4 Absolute Maximum Ratings

AMBIENT TEMPERATURE UNDER BIAS	0°C	TO	70°C
STORAGE TEMPERATURE	-40°C	TO	125°C
VOLTAGE ON ALL INPUT AND OUTPUTS WITH RESPECT TO VSS	-0.5V	TO	7V

#### 5 Standard Test Conditions

The characteristics below apply for the following standard test conditions. Unless otherwise noted. All voltages are referred to VSS (0V GROUND), positive current flows into the referred pin.

OPERATING TEMPERATURE RANGE	0°C	TO	70°C
POWER SUPPLY VOLTAGE	4.75V	TO	5.25V

#### 6 D.C. Characteristics

Symbol	Parameter	Min.	Typ.	Max.	Units	Conditions
VIL	INPUT LOW VOLTAGE	VSS	-	0.8	V	VCC=5V
VIH	INPUT HIGH VOLTAGE	2.0	-	VCC	V	VCC=5V
IIL	INPUT LOW CURRENT	-	-	-0.5	uA	VIN=1.0V
IIH	INPUT HIGH CURRENT	-	-	20	uA	VIN=VCC
VOL	OUTPUT LOW VOLTAGE	-	-	0.4	V	IOL=8.0mA
VOH	OUTPUT HIGH VOLTAGE	2.4	-	-	V	IOH=4.0mA
ICC	SUPPLY CURRENT	-	35	-	mA	VCC=5V

## 7 Physical Dimensions

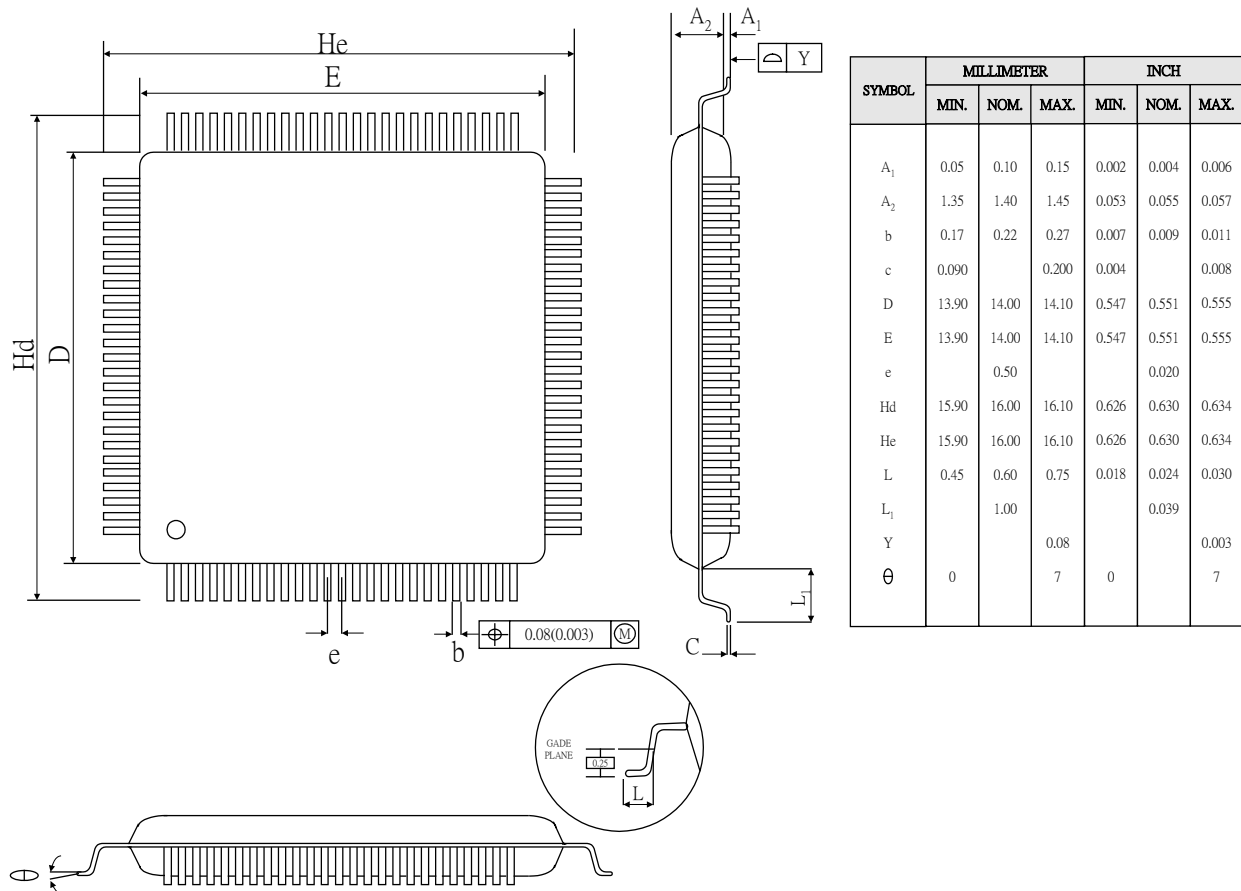

### Notice

Information in this document is subject to change without notice. ICPLUS reserves the rights to change its products at any time. Therefore, the customer is cautioned to confirm with ICPLUS regarding the latest released version before placing orders.

ICPLUS devices are NOT designed, intended, authorized, or warranted to be suitable for use in Life-Supporting applications.

### IC Plus Corp.

#### Headquarters

10F, No.47, Lane 2, Kwang-Fu Road, Sec. 2,  
Hsin-Chu City, Taiwan 300, R.O.C.

TEL : 886-3-575-0275 FAX : 886-3-575-0475

Website: [www.icplus.com.tw](http://www.icplus.com.tw)

#### Sales Office

4F, No. 106, Hsin-Tai-Wu Road, Sec.1,  
Hsi-Chih, Taipei Hsien, Taiwan 221, R.O.C.

TEL : 886-2-2696-1669 FAX : 886-2-2696-2220